



VIRGINIA GUN COLLECTORS ASSOC., INC.

WWW.VGCA.NET

Est. 1983 (A Not-for-Profit Organization)

NRA Affiliate Number G8162

CMP Affiliate Number 026160



President
Show/Reservations Manager
Membership

Bernie Breighner
Rick Nahas
Bill Chronister

Phone: 703-200-0470
Cell: 571-215-8761
Phone: 703-204-0138

BFBKAC@gmail.com
jet53sw@aol.com
Vgca_membership@cox.net

Website: www.vgca.net
Facebook: @VirginiaGunCollectorsAssoc

Twitter: @VAGunCollectrs
Instagram: @vaguncollectors

February 2021 VGCA Newsletter

President's Comments

VGCA Members,

We just had our first “virtual” membership meeting last night – including a great presentation by member Jim Ashing on Colt Boxes. I think it went really well and we received some very positive comments. One thing we all noticed is that it’s much easier to see the presentation on your computer than during an in-person membership meeting. This is still a project in the works - there are some technical as well as copyright concerns going forward. But we think this is a great idea that will allow us to reach members that cannot attend in person. We did have over 45 members in attendance at the first meeting. Please submit feedback good or bad on the webinar and we will try to improve the product. Many thanks to Shannon, Wes and Andrew for all the technical aspects of the meeting.

The process itself of logging on is fairly easy if you have access to a smart phone, laptop or desktop computer. Once you have the email invite it’s just a matter of clicking the link at meeting time. We also are allowing members to log on early and depending on your set up, you may be able to talk and see other members. Our plan is for another virtual meeting in April. The invite will be sent out via the VGCA constant contact email approximately 7 days before the meeting.

The other big news is our March 27-28 gun show is on! The board discussed the pros and cons and voted in favor of having the show. We will use the same COVID safety protocols as the November show. There are only a couple of tables available. If you have a table reservation and do not feel comfortable participating, please let Rick know as soon as possible and we will roll your reservation to November Gun show.

Everyone please stay safe and I look forward to seeing you at the March gun show.

—*Bernie Breighner*, VGCA President



EMILIO GHISONI'S REVOLVERS: THE MATEBA MTR-8 TO THE MODEL 6 UNICA

By Marc Gorelick



Emilio Ghisoni was an imaginative designer of revolutionary revolvers. Ghisoni was born in Pavia, northern Italy in 1937. His father had started a company, Macchine Termo-Balistiche (Mateba), that manufactured pasta kneading and food processing machinery. Although he had a talent for engineering Ghisoni went to university to major in classics. Ghisoni's classical studies were cut short when his father died in 1956 and he returned home to take over the company. He later became a mechanical engineer and prolific designer of food processing equipment. He was an avid firearms enthusiast and shooter with an interest in designing revolvers in order to improve accuracy in international rapid-fire competitions. He believed that by lowering the barrel and aligning it with the lower chamber of the cylinder instead of the upper

chamber he would lower the bore axis, put the recoil force in line with the shooter's arm and minimize muzzle rise due to recoil.

Ghisoni produced his first revolver in the 1970's. This prototype's design set the stage for his future designs with a low axis barrel and cylinder mounted in front of the trigger guard. He followed this initial design with:

- The Mateba MT1, a .22 LR semi-automatic pistol, produced in small numbers in 1980.
- Mateba MTR-8, produced in 1983.
- Mateba 2006M.
- Mateba Model 6 UNICA Autorevolver.
- Chiappa Rhino revolver.

According to one Italian source, Ghisoni, who died in 2008, was a talented and imaginative designer but a poor firearms businessman. He did not seem to be really interested in selling his guns, only designing them and made only very limited production runs before passing on to another firearms project. His primary business was designing and manufacturing food processing machinery and designing guns was almost a hobby.

THE MATEBA MTR-8 AND MTR SERIES

The Mateba MTR-8 is Ghisoni's first production revolver. Like the MT1 semi-automatic pistol, the MTR series of revolvers was designed for competition target shooting, especially for rapid-fire events. It exhibits many of the trademark Ghisoni features as his unique firearms philosophies began to surface with this weapon. It is a double/single action revolver of all-steel construction.

The bore axis is relatively low, and the weight is distributed towards the front, reducing muzzle flip, and minimizing barrel rise to and making it easier for target shooters to make quick follow-up shots. To lower the bore axis and move the weight forward, Ghisoni placed the cylinder in front of the trigger guard and lower down. This decoupled the cylinder from the lockwork and allowed a quite narrow frame with a

large cylinder. Although the barrel was aligned with the top chamber of the cylinder, it was still low enough to put the recoil force in line with the shooter's arm, thus reducing felt recoil.

Ghisoni also used a larger, higher capacity cylinder, which added to the forward weight and also reduced perceived recoil. The MTR-8 cylinder contained 8 rounds of .357 or .38 caliber ammunition, the MTR-12 cylinder held 12 rounds of .32 caliber ammunition, and the MTR-14 cylinder chambered 14 rounds of .22LR. The cylinder swings out to the left for reloading, the cylinder release latch is located at the front of the cylinder on the cylinder crane, and the cylinder is opened by pushing down on the latch.



Mateba MTR-8 revolver. Right side. Photo courtesy of Joh. Springer's Erben of Vienna Austria.



Mateba MTR-8 revolver. Left side. Note cylinder latch on the cylinder crane in front of the cylinder. Photo courtesy of Joh. Springer's Erben of Vienna Austria.

The weapon's loading procedure is rather unusual and designed to speed reloading. A two-part clamshell-like disc is preloaded and holds the rounds in place much like a speedloader. This is used to insert the rounds into the rear of the cylinder's chambers, but the loader remains in place, much like the half-moon clips for the .45 caliber U.S. Model 1917 revolver. The gun will not fire without the loading clip being in place.

The MTR-8's action, including the trigger unit's design is unusual – it has a sliding trigger like a Model 1911 rather than a traditional revolver's hinged trigger. The hammer is entirely shrouded and concealed within the frame and is located in the grip, with the long firing pin passing above the trigger, towards the rear of the cylinder. The hammer can be manually cocked and de-cocked by a small thumb lever located above the left grip panel.

There were a number of variants of the MTR-8. Those in calibers other than .38 are extremely rare and may have been experimental or prototypes.

- MTR-8 - .38 Special, eight round capacity
- MTR-8M - .357 magnum, eight round capacity
- MTR-12 - .32 S&W, twelve round capacity
- MTR-14 - .22 LR, fourteen round capacity
- MTRC-x - carbine variants of the above revolvers, with some models featuring increased ammo capacity.

Although one Italian source claimed that the MTR revolvers were intended for personal defensive it appears that they had limited use outside of competition or target shooting. They were too heavy and too long for everyday concealed or open carry. The gun was reliable, but had a fragile striker that tended to break. The exact number of MTR-8s produced is unknown – according to an Italian source it is estimated to be between 300 and 400 guns. U.S. sources say that as many as 500 were manufactured. Most were apparently exported to Germany and Switzerland and production ended in 1986.

THE MATEBA 2006M



Mateba 2006M. Photo Public Domain per Creative Commons CC0 1.0 Universal Public Domain Dedication.

The Mateba 2006M was originally developed as a successor to the Mateba MTR series and can be said to be a transitional design between the more famous MTR-8 and the Model 6 Unica Autorevolver. Originally called the MTR-6, it initially had a hollow grip. The design and name were changed several times and the Mateba MTR 6+6 version was introduced in 1985. The MTR-6+6 was chambered for .38 Special/.357 Magnum; the “6+6” designation came from the 6-round cylinder and the grip, which was hollow and contained 6 rounds in a full-moon-type clip for quick reloading. MTR-6+6 was not built in any great numbers and is still relatively not well-known.

By 2000 Ghisoni had perfected the design and the MTR-6 reached its final form as the 2006M. Although the Mateba 2006M bore only a superficial external resemblance to the original Mateba the mechanism was essentially the same. The Mateba 2006M is chambered for .38 Special/.357 Magnum and has a 6-round cylinder. The hollow grip was abandoned and it has different rear sights. There are several variations with different barrel lengths. 2007M barrels came in 2, 3, and 4 inches, and these barrels could be easily swapped. The 2007S version was introduced with a 7-round cylinder capacity, but fires only .38 Special ammunition, and the barrels are 3, 4, or 6 inches long. A .44 Special/.44 Magnum version of the 2006M was later introduced, and the barrel lengths were expanded to include 6 and 8 inches. In addition, compensated barrels are available for the 4, 6, and 8-inch barrels of the 2006M.

The 2006M is the first of Ghisoni's revolvers to use the distinctive 6 o' clock bore position with the barrel aligned with the bottom chamber of the cylinder. Ghisoni moved the cylinder back to the traditional position above the trigger and triggerguard. Unlike many other revolvers, the cylinder rotates counterclockwise when firing. Also, unlike most other revolvers the side-opening cylinder hinges upwards. Another unusual feature is the cylinder release, which is a rotating lever. The cylinder is released when the lever is pushed forward.

THE MATEBA MODEL 6 UNICA AUTOREVOLVER



Mateba Model 6 Unica Autorevolver. Photo by LoCo CNC.

The Mateba Model 6 Unica (also known as the Mateba Autorevolver) is a recoil operated semi-automatic revolver. The gun uses the recoil from firing to rotate the cylinder and cock the hammer, unlike conventional revolvers, where the shooter has to physically pull the trigger (double action) or cock the hammer (single action) in order to rotate the cylinder and bring the gun into battery. This unique action makes the Model 6 Unica one of the very few semi-automatic revolver designs. The Webley–Fosbery Self-Cocking Automatic Revolver, designed by Lt, Col. George Vincent Fosbery VC and manufactured by Webley & Scott from 1901 to 1924 is another notable example of a semi-automatic revolver.

The barrel follows Ghisoni's trademark design principal and the bore is aligned with the bottom chamber of the cylinder in order to direct the recoil directly back to the shooter's arm and minimize muzzle flip and perceived recoil. The gun's entire upper assembly consists of the barrel, cylinder and frame. It is mounted on rails that are machined on the lower frame, which houses the trigger, hammer, and grip. The upper assembly recoils backward when the pistol is fired and the rearward motion cocks the hammer. The cylinder is rotated into battery on the forward stroke of the upper assembly.



Photo left. Mateba Model 6 Unica, top and rear view. Note absence of a top strap connecting the barrel with the rear frame. Also note low position of the barrel and the flat sided cylinder. Photo by Argentus, Creative Commons Attribution-Share Alike 3.0 Unported license.

Ghisoni's US Patent 4,712,466 dated Dec. 18, 1987 describes the action thusly:

“A revolving cylinder pistol comprising a mount containing the firing mechanism and a slide carrying the barrel and cylinder. The slide is guided movably on the frame between two mechanical stops. Each recoil stroke of the slide automatically energizes a spring motor carried in the slide itself which is effective to cause the cylinder to revolve in timed relationship with the pistol cocking. The mount supports a pusher which can energize said spring motor on request and is operated by the reload mechanism.”

The hammer is partly concealed in the frame and the 6-chambered cylinder is not perfectly round, but rather has somewhat flat sides with rounded corners. This is intended to reduce the gun's profile in concealed carry. A feature of the pistol is that there is no topstrap above the cylinder, probably because of the sliding action of the barrel and cylinder against the rear frame of the lower assembly. Also, the low position of the barrel relieves the upper part of the cylinder and frame of pressure. The cylinder is mounted on a crane which swings out to the left for loading and unloading. The Model 6 Unica pistol comes in four variants with a number of different chamberings and barrel lengths. The variants are:

- Defense - 4" Barrel, .357 Magnum
- Home Protection - 5" Barrel, .44 Remington Magnum
- Dynamic Sportiva - 5" or 6" barrel, .357 Magnum
- Hunter - 8 3/8" Barrel, in .44 S&W Special or .44 Remington Magnum

Different length barrels are interchangeable. There is also a version chambered in .454 Casull and a carbine version – the Mateba Grifone. This has an 18-inch barrel, hand guard and butt stock mated to the Autorevolver's frame and action. The Grifone was available in .357 Magnum, .44 Magnum, and .454 Casull, which allows it to fire .45 automatic. Mateba Autorevolvers chambered in .357 Magnum can be loaded with .38 Special ammunition but because most .38 Special loads do not have enough power to fully cycle the recoil mechanism special springs have to be installed.

The Model 6 Unica was produced between 1997 and 2005. The Mateba name was recently purchased by an Italian investment group that is reviving the original pistol lines as well as manufacturing AR-type rifles and precision rifles.

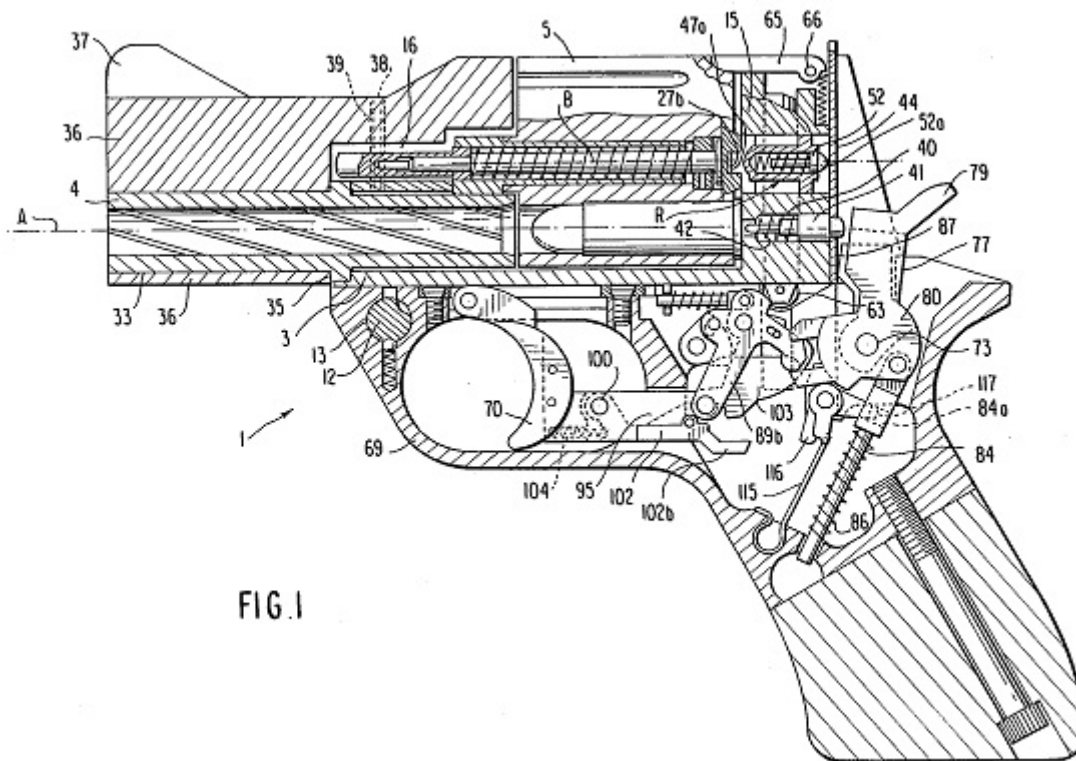

FIG. 1

One of 10 patent drawings from Ghisoni's US Patent 4,712,466 for the Mateba Model 6 Unica.

AND THEN CAME THE RHINO



The Chiappa Rhino revolver (see photo to the left of a Model 40DS – Photo Chiappa Firearms) is made by Chiappa Firearms (Armi Sport di Chiappa), an Italian firearms manufacturer in Brescia, Italy. Armi Sport is the firearms manufacturing branch and is also known for its extensive line of reproduction guns. It is no coincidence that the Rhino bears a striking resemblance to the Mateba 2006M and Model 6 Unica. That is because Emilio Ghisoni was one of the two designers and the Rhino

bears many of his signature features as well as being stylistically similar to his earlier handguns. (The other Rhino designer was Antonio Cudazzo.) The Rhino's barrel is on a low bore axis and the gun fires from the bottom chamber of the cylinder, both features of Ghisoni's pistols. Another distinctive feature is the shape of the cylinder; it has flat sides with rounded corners, much like the cylinder of the Model 6 Unica Autorevolver. The Rhino is made in a number of different calibers and barrel lengths, and was Ghisoni's last firearm design before his death in 2008.

GUNS OF DISTINCTION

HOLLAND & HOLLAND ROYAL DOUBLE RIFLE

By Marc Gorelick

Photos courtesy of Joh. Springer's Erben, Vienna, Austria



In the world of top quality custom gunmakers, the British firm of Holland and Holland, established in 1835, is second to none. Today, a new hand-built bespoke gun from Holland & Holland can cost \$76,000 for a shotgun and \$126,000 for some rifles, with price increases for luxury engraving, and with a wait of two to three years from order to delivery.



This Royal model side by side double barrel rifle in .375 H&H was made as one of a pair in 1932. It has 25-inch chopper lump barrels made and signed by Joseph Brazier - Ashes, a file-cut quarter rib, express sights with additional folding leaf, front sight with folding hood and night bead. The bright action has arcaded fences, side bolsters, and hand-detachable back-action sidelocks, all decorated with exquisitely

bold Royal Grade engraving. It has gold inlaid cocking indicators, automatic sliding tang safety with gold inlaid "Safe" and double triggers with articulated front blade.



This luxurious big game rifle has a well grained walnut stock with drop points, oval cheekpiece, and blank gold stock oval. The triggerguard and other metal parts are engraved and the engraved steel pistol grip cap has a trap. All parts are gold inlaid with the number "2."



This exquisite firearms was offered at auction by the illustrious house of Joh. Springer in Vienna, Austria with a starting price of \$33,941 (28,000 Euros). It came with an oak and leather case by the maker with the trade label (Bruton Street address) and individual label (New Bond Street address), and a Swarovski Z6i 2-12x50 scope.



IMPORTANT
RIFLE NO. 32183.

This Rifle is regulated for Holland & Holland's
375 Nag Kimber cartridge.

Extract from the "Field," 11th April, 1929.
"PITFALLS IN THE INDIAN JUNGLE."
Never use stale ammunition. Get a fresh lot from a reputable firm for each shoot and throw away what remains after returning home. Insist on a guarantee that it is freshly imported.

NOTE.

The first shot fired out of a clean and oily barrel is liable to go high. To avoid this, fire a shot out of each barrel before using the Rifle at game; or, if this is not convenient, care should be taken to wipe the barrel out quite dry and free from oil before use.

Holland & Holland's Guns, Rifles and Ammunition can usually be obtained from the leading Gun makers in India.

HOLLAND & HOLLAND, LTD.,
GUNMAKERS TO HIS MAJESTY KING GEORGE V.
98, NEW BOND STREET, LONDON, W.1.



Round 2 of the CMP's 1911 Sales Program started in January. This is your chance to purchase a surplus M1911A1, however you must act quickly because orders postmarked after **March 4, 2021** will not be accepted. Go to the CMP website at <https://thecmp.org/sales-and-service/1911-information/> for the latest update and instructions on how to put in your order for a 1911. Make sure you are using the correct **CMP 1911 UNIVERSAL ORDER FORMS**, in the top right corner under the pistol, it will say **ROUND 2**. The instructions provide a link to the correct order form. When filling out the order form be sure to follow the instructions carefully.

You can only order ONE 1911 from the CMP. If you already received a 1911 from the first round or through the Auction site, then you cannot order another 1911.

Potential purchasers will have to provide **CMP 1911** with a set of CMP 1911 documents exhibiting: 1) proof of U.S. Citizenship, 2) proof of membership in a CMP affiliated club, 3) proof of participation in a marksmanship activity, 4) a completed 1911 order form, including a new form 2A with notary. All qualifying documents must be included in your order packet.

TIPS FOR COMPLETING THE ROUND 2 ORDER FORM PACKET

- **Please read all the instructions.**
- Make sure you are using the correct **CMP 1911 UNIVERSAL ORDER FORMS**, in the top right corner under the pistol, it will say **ROUND 2**.
- Just insert the asked for information in the space provided. **DON'T READ MORE INTO THE QUESTION THAN IT ASKS FOR.**

- Where it asks for the FFL Name on the order form, that's simply all we want, the name of the FFL to where you plan to have the pistol shipped once your order is processed. **Note: it doesn't say license #, address, etc.** Just put the name of the FFL you PLAN on using to receive the pistol...that's it! – **"FFL information"** means the actual FFL data, address and license verification that is provided once your RGN comes up and your order is processed. **DON'T OVERTHINK IT.**
- CMP (RIFLES) records will not transfer to CMP 1911, they are 2 separate entities. Your CMP customer number is not valid for CMP 1911.
- The 2A Form **MUST** be notarized in order to be accepted and to purchase a CMP 1911.
- The CMP cannot accept a "Virtual Notary."
- The Virginia Gun Collectors Association (VGCA) is an acceptable CMP affiliated organization and can be used.
- At this time, we still cannot ship to the state of Massachusetts.
- With current problems the U.S. Postal Service is having, the CMP suggests that you send your order packet by Fed Ex or UPS.
- Please do not send your order packet "Signature Required." Half the time all the Post Person does is drop a notice in our mail box requiring that we go to the Post office to pick it up, we have neither the staff nor time to do so. The CMP suggests that you use Fed Ex or UPS as they provide a tracking number.
- It does not matter what color ink you use to fill out the order packet, only that the CMP can read your writing.

CMP 1911 FFL CONTACT INFORMATION DETAILS:

At the time a customer is contacted they will be asked to submit a current FFL where their pistol will be sent. All 1911's will be shipped to a 01, 02 or 07 Federal Firearms License. Customers will have 5 business days from when contacted to provide **CMP 1911** with a signed FFL.

Only FFLs with normal business hours may be used. Due to COVID 19, CMP 1911 can only ship to an FFL that is opened during normal business hours in order to lessen the possibility of the pistol being stolen. Pistols cannot be "held" at a Fed Ex location and, if not delivered, will be returned to CMP 1911.

CMP 1911's dedicated fax number for FFL dealers to fax their FFLs with the customer's name attached is **(256) 831-2354**.

CMP 1911's dedicated email address for FFL dealers to send their FFLs with customer's name attached is cmp1911FFL@thecmp.org.

A NICS background check on each customer will be performed by the FBI to assure the customer is eligible to purchase prior to shipment to the FFL licensed dealer. The customer must receive a "proceed" from NICS prior to shipment of the pistol to the FFL licensed dealer.

The **CMP1911** customer will be required to complete a Form 4473 in person at the FFL dealer's place of business and successfully pass a NICS check, in which the information is provided by the FFL holder to NICS, before the pistol can be transferred. This is a second NICS check performed on the customer.

★ **ATTENTION MEMBERS: Have you the authored a book/magazine article, or published research on Firearms, Gun Collecting, History, or related subjects?**

The VGCA is fortunate to have a diverse membership with a large amount of expertise, experience, and knowledge! If you are - or know any member who is - a published author or researcher, please know that the Virginia Gun Collectors Association, Inc. wants to feature your works on the VGCA website, at gun shows, in the VGCA newsletters (see the FOR SALE section of this newsletter), and/or at VGCA meetings. We also invite you to consider giving a presentation on your works at one of our meetings. If you have any questions or wish to be included, please direct any information, including titles, publishing information, or contact information to: Bill Chronister, Membership Chairman at vgca_membership@cox.net or at home on 703-204-0138.

★ **Show-n-Tell** ★

NOTE – If you would like to feature something new (or old) from your collection in a future VGCA newsletter, please send 1-4 photos, along with a description of the item to rpebecker@verizon.net. A Show-n-Tell Fact Sheet (below) lists the information we would like in order to adequately describe your prized possessions.

VGCA Show-n-Tell Fact Sheet

Manufacturer: _____

Model: _____ Action Type: _____

Caliber: _____

Years of Production: _____ Total Produced: _____

Year this example was manufactured (if known): _____

Significance: _____

Question(s) for members: _____

Name (optional): _____

Where acquired (optional): _____ When acquired (optional): _____

Member 1 shared this Walther PP in 7.65 mm (.32 ACP) manufactured in April 1945. His description follows:



I came across this pistol in a gun shop in Boise, ID. I moved there last summer, and, of course, had to go check out the shops there. It was sitting in a display case next to a new PPK/S stainless. Seeing that it was obviously fairly old, I asked to take a look at it. It was tagged as a

"PPK .380," but it had no manufacturer's roll marks on the slide, nor any proof marks. Just mismatched serial numbers and "ac" on the slide and frame, which I knew was Walther as I have an "ac" P-38 (and not a copy of some sort). I asked the clerk how old it was, and he said he wasn't sure, but "50s or 60s." Though I am by no means an expert, I had a hunch it was older. I copied the serial numbers, went to the car, and did a little research. When I realized what it was, I ran back in and bought it!



As many members may already know, this Walther PP is a late war "mismatched" capture from the Walther factory in Zella-Mehlis in April 1945. As referenced in the articles and videos linked below, these "ac" PPs were in the serial range of 370000P - 397000P, and were captured unfinished at the factory. Because they were in various stages of production when the 11th Armored Division captured the factory on April, 4, 1945, many were assembled from parts still in bins, thus the mismatched slides and frames. These have been called "correct mismatches" because that is how they left the factory. They may have the "ac" Walther factory code marking on the slide or none at all. Some are blued, some in the "white," and some parkerized. It just depends where they were in the production process when the factory was captured. Some were assembled by GIs as they went through the factory when they couldn't find a complete pistol, of which there had been many P-38s, PPKs, PPs, and various other firearms. Others were apparently traded for cigarettes with workers who returned to the factory to help the Americans package and ship the thousands of captured weapons, and dubbed "cigarette guns." While it will never be known for certain, I have read where there were only about 1200-1700 mismatched PPs that left Zelle-Mehlis.

The flat-bottomed magazine (*at right*) is late war factory-issued. The "W" stands for "weich," or malleable, or unhardened.

As for the ivory-colored grips (*see pictures above*), they were made by Franizte/Chicago Inc. in the 1950s as far as I can tell. I'm keeping them. They're part of the story, whatever it is.

And for what it's worth, it shoots great!

Any additional information by VCGA members to add or correct the information I have written here is greatly appreciated.



★ Upcoming Events and Shows ★

PLEASE NOTE: Gun Shows are in a state of flux as states re-impose restrictions on public gatherings. Members are strongly encouraged to verify shows before driving to an event. These dates were verified when this newsletter was written, but are not guaranteed.

VIRGINIA – 2021

- ~~Mar 12-14, 2021 – Chantilly, VA – Dulles Expo Center – Showmasters - CANCELLED~~
- Mar 13-14, 2021 - Fredericksburg, VA – Fredericksburg Expo & Convention Center – SGK
- Mar 21-22, 2021 – Hampton, VA – Hampton Ro ADS Convention Center – SGK
- Mar 20-21, 2021 – Roanoke, VA – The Berglund Center - Showmasters
- Mar 27-28, 2021 – Richmond, VA - Richmond International Raceway – Showmasters
- Mar 27-28, 2021 – Manassas, VA – PWC Fairgrounds – VGCA (OUR SPRING SHOW!)
- Apr 10-11, 2021 – Doswell, VA – Meadow Event Park – SGK
- Apr 10-11, 2021 – Fishersville, VA – Augusta Expo – Showmasters
- Apr 17-18, 2021 – Virginia Beach, VA – Virginia Beach Convention Center - SGK
- Apr 23-25, 2021 – Chantilly, VA – Dulles Expo Center – Showmasters
- May 1-2, 2021 - Fredericksburg, VA – Fredericksburg Expo & Convention Center – SGK

MARYLAND – 2021

- ~~Mar 20-21, 2021 – Timonium, MD – Maryland State Fairgrounds – Maryland Arms Collectors Association – CANCELLED~~
- ~~Mar 26-27, 2021 – Edgewood, MD – Edgewood American Legion – American Legion Post 17 – CANCELLED~~
- Apr 10-11, 2021 – Frederick, MD – Frederick Fairgrounds - Appalachian Promotions
- Apr 17-18, 2021 – Timonium, MD – Timonium Fairgrounds - Appalachian Promotions
- May 15-16, 2021 – West Friendship, MD – Howard County Fairgrounds – Appalachian Promotions

PENNSYLVANIA – 2021

- Mar 5-6, 2021 – Gettysburg, PA – Gettysburg Fire Dept – Hallowed Ground Militaria – Gettysburg Militaria & Historic Arms Show
- Mar 6-7, 2021 - Gettysburg, PA – All-Star Sports Complex – Eagle Arms
- Mar 6-7, 2021 – Allentown, PA – Parkview Inn & Conference Center – Eagle Arms
- Mar 6-7, 2021 – Leesport, PA – Leesport Farmers Market – Appalachian Promotions
- ~~Mar 6-7, 2021 – Hermitage, PA – Hickory Post VFW – L&R Sporting Events - CANCELLED~~
- Mar 6-7, 2021 – St Thomas, PA – St Thomas Volunteer Fire Dept – Frontier County Gun Club
- Mar 13-14, 2021 – East Berlin, PA – East Berlin Fish & Game – East Berlin Fish & Game
- ~~Mar 13-14, 2021 – Harrisburg, PA – PA Farm Show Complex – C&E Gun Shows - CANCELLED~~
- Mar 13-14, 2021 – Quarryville, PA – Solanco Fairgrounds – SLCFSA
- Mar 14, 2021 – Portland, PA – William Pensyl Social Hall – Portland Hook & Ladder Co. #1
- ~~Mar 20-21, 2021 – Harborcreek, PA – Harborcreek Fire Dept – L&R Sporting Events – CANCELLED~~
- Mar 20-21, 2021 – Spring Brook, PA – Spring Brook Fire Dept - Jaeger Arms
- Mar 27-28, 2021 – East Stroudsburg, PA – VFW Post #2540 - Jaeger Arms
- Mar 27-28, 2021 – Gettysburg, PA – Redding Auction – Central Pennsylvania Antique Arms Association

- Apr 10-11, 2021 – Washington, PA – Washington County Fairgrounds – *ARH Sport Shop*
- Apr 17-18, 2021 – Centre Hall, PA – Centre County Grange Fairgrounds – *Outdoor Sportsman Club*

PENNSYLVANIA – 2021 (continued)

- Apr 17-18, 2021 – Gettysburg, PA – All-Star Sports Complex – *North South Trader’s Civil War Magazine*
- Apr 17-18, 2021 – Sellersville, PA – Forrest Lodge VFW Hall & Club - *Jaeger Arms*
- Apr 24-25, 2021 – Lewis Run, PA – Lewis Run VFD Station 6 – *Lewis Run Vol Fire Dept*
- May 7-9, 2021 – Long Pond, PA – Pocono Raceway – *Tall Timber Tactical*
- May 16, 2021 – Portland, PA – William Pensyl Social Hall – *Portland Hook & Ladder Co. #1*

SPECIAL EVENTS / SHOWS - 2021

- Mar 13-14, 2021 – Wilmington, OH – Roberts Convention Centre – *Ohio Gun Collectors Assoc*
- May 8-9, 2021 – Wilmington, OH – Roberts Convention Centre – *Ohio Gun Collectors Assoc – Annual OGCA Display Show*
- Jul 21-25, 2021 – Louisville, KY – Kentucky Expo Center - *OVMS– Show of Shows*

FOR SALE:

The "For Sale" section of the Virginia Gun Collectors Association (VGCA) Newsletter is provided as a service exclusively to the members of the VGCA. The VGCA, its officers, and directors are not responsible for any listings made in any VGCA Newsletter. We are not responsible for the accuracy (condition, value, etc.) of any listings. All buyers, traders, and sellers agree to comply with all local, state, federal, and international laws in regards to items sold via the VGCA Newsletter. It is their duty and responsibility to ensure the quality and value of the transaction and that all such laws are followed at all times. Buy, sell, or trade at your own risk.

If you would like to list an item (or items) in the VGCA Newsletter, please send your description, price, and contact information to rpebecker@verizon.net. I must receive your material no later than the second Sunday of the month for it to be included in that month’s newsletter. Unless other arrangements are made, items will be listed for one issue of the Newsletter.

FOR SALE:

✦ VGCA member Charlie Pate has four books that he has authored for sale, at discounted prices to VGCA members. These include:

- “U.S. Handguns of World War II” - \$45.00
- “The Smith & Wesson American Model” - \$55.00
- “U.S. Military Arms Inspector Marks” - \$45.00
- “The Colt Model 1860 Army Revolver” - \$60.00

If interested, please contact Charlie at usarmsresearch@gmail.com

FOR SALE:

✦ After more than two and a half years of research, VGCA member Bill Vanderpool has recently published his book “Guns of the FBI”. This book is available at GunDigest.com or can be purchased directly from Bill by calling 703-626-2975. He is more than happy to sign a copy for you. Cost is \$50.00.

FOR SALE:

★ Original Colt 1862 Pocket Navy, 5-shot .36 caliber. VGC. Includes original Colt bullet mold, Colt screwdriver and nipple wrench, original period powder flask, Eley cap tin and Taylor display case. ~~\$2750~~ Now \$2595

★ Anthony Vanderlinden autographed book "FN Mauser Rifles-Arming Belgium and the World" \$100.

★ Factory lettered Antique Smith & Wesson Revolvers

a. 1865 Model 1-1/2 First Issue .32rf 5-shot nickel plated, rosewood grips matching numbers including grips. Smaller version of Army #2. \$795

b. .38cf 1877 Baby Russian 5-shot, rare 4 inch barrel, matching numbers including grips, early block lettered monogrammed grips, nickel plated. \$1750.

c. Unique MODEL of 1891 w/ scarce 5 inch barrel, nickel plated 5-shot, .38cf, full triggerguard, pearl grips, shipped from factory in 1893. \$2350.

If interested, call 571-308-4978 or send email to jrbzn13@aol.com

FOR SALE:

★ VGCA member Terry Philipppy offered up this book as a tribute to his mother-in-law:
- "The Army Air Corps: Branch Immaterial – A World War II Memoir"

\$16.80 (Amazon) or \$20.95 (Barnes & Noble)

Available on-line at Amazon: https://www.amazon.com/Army-Air-Corps-Branch-Immaterial/dp/164416664X/ref=sr_1_1?crd=3I6NIEYEG74BB&dchild=1&keywords=branch+immaterial&qid=1592941069&sprefix=branch+imm%2Caps%2C156&sr=8-1

Also available from Barnes and Noble: <https://www.barnesandnoble.com/w/the-army-air-corps-colonel-w-g-bonvouloir/1131936753?ean=9781644166642>

FOR SALE:

★ RCBS Rock Chucker reloading press with choice of one die set (.303 Savage, .224 Weatherby Magnum, .32 Winchester Special, .219 Donaldson Wasp, .308 Winchester, or .30/06 Gov't) - \$125.00. Extra die set for \$20 each.

★ FN P90 50-round Magazines. NIB. \$45.00 each



★ Madsen Model 50 30-round 9mm Magazine. \$75.00



★ .30/06 Springfield Ammo. Winchester 150 grain Power Point. 20 round box. \$20



- ★ .40 S&W Ammo. Remington 155 grain JHP. \$20



- ★ .40 S&W Ammo. Corbon 150 grain JHP. \$20



- ★ .40 S&W Ammo. Mixed – including Black Talon. 43 rounds. \$50

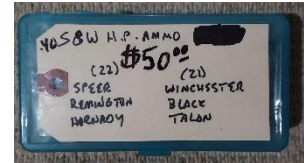

- ★ .450 Nitro Express Ammo. Hornady 3 ¼ 450 grain DGX. \$100

Prices firm. Contact Jack for details at looney.house@verizon.net

FOR SALE:

★ S&W Model 4013 TSW in .40SW, 3 DOT Tritium Night Sights, Walt Freer Trigger Job, Hoge Grips, new Milt Sparks Black Leather Holster, new Mixon Black Leather 2-Mag Belt Pouch, 2 x 12-round S&W Magazines, 8 x 9-round S&W Magazines, soft side pistol bag, and over 300 rounds of .40SW ammo. Entire Package ~~\$600.00~~ ~~\$550.00~~ Last price drop - now \$500.00!

Buyer must have a Virginia CHP, be a credentialed LEO, or submit to a Virginia State Police background check. If interested, call John at 703-281-2478.

FOR SALE:

★ One brand new Box of 50 rounds of Winchester .357 Sig Ammo (125 Grain FMJ). Purchased recently at Green Top by mistake - paid \$50 and will take \$50 for it

If interested, call Joe at 571-278-3297.

WANT TO BUY:

★ Member Joe Carson of Stafford, VA is looking to buy an Enfield No. 4 Mk I or No. 4 Mk I* manufactured by Long Branch. He is looking for VG-Excellent condition rifle that he can use as a shooter. If you have one for sale, please contact Joe at joe31968@yahoo.com

The e-mail address for any Newsletter-related matters is Newsletter@vgca.net - or you can reach the editor directly at rpebecker@verizon.net. Feel free to e-mail items for inclusion in the newsletter. For changes of address or non-receipt of the newsletter, either via e-mail or the mailed hard copy, please contact Rob Becker or Bill Chronister.